

Ramp / Handicap Accessible

The attached information and drawings are provided for your information as it pertains to ramp requirements. This information and these drawings do not depict all possible configurations.

Ramps for private homes (individual single family dwellings - SFD) serving the egress (front) door may be no steeper than 1:12 and other SFD ramps may be no steeper than 1:8. SFD ramps may be as narrow as 36" in width, may have a single handrail, may have 36" x 36" landings and other dimensional criteria as described and shown below.

Ramps for multi-family dwellings and commercial applications must meet all commercial handicap specifications.

GENERAL REQUIREMENTS

Slope ¹	Maximum Rise
Steeper than 1:10 but not steeper than 1:8	3 inches (75 mm)
Steeper than 1:12 but not steeper than 1:10	6 inches (150 mm)

¹A slope steeper than 1:8 shall not be permitted.

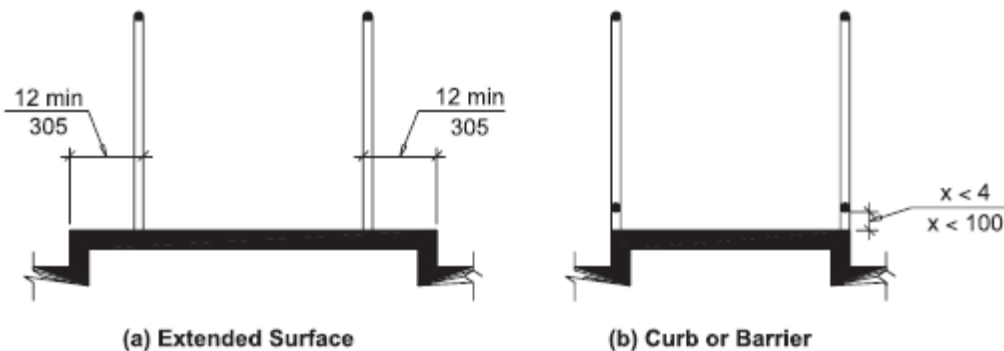
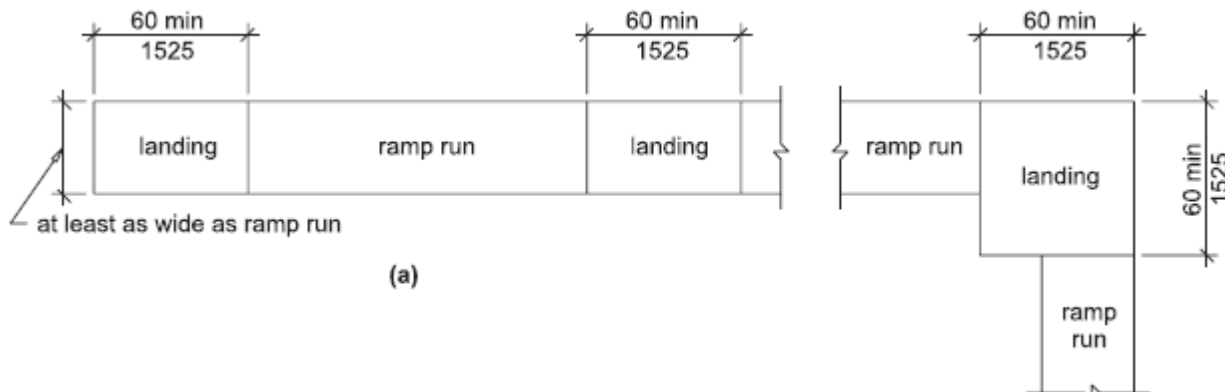
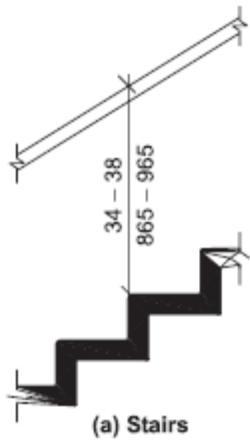
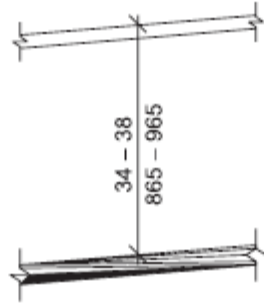

Fig. 405.9
Ramp Edge Protection



(a) Stairs



(b) Ramps

**Fig. 505.4
Handrail Height**



**Fig. 505.5
Handrail Clearance**

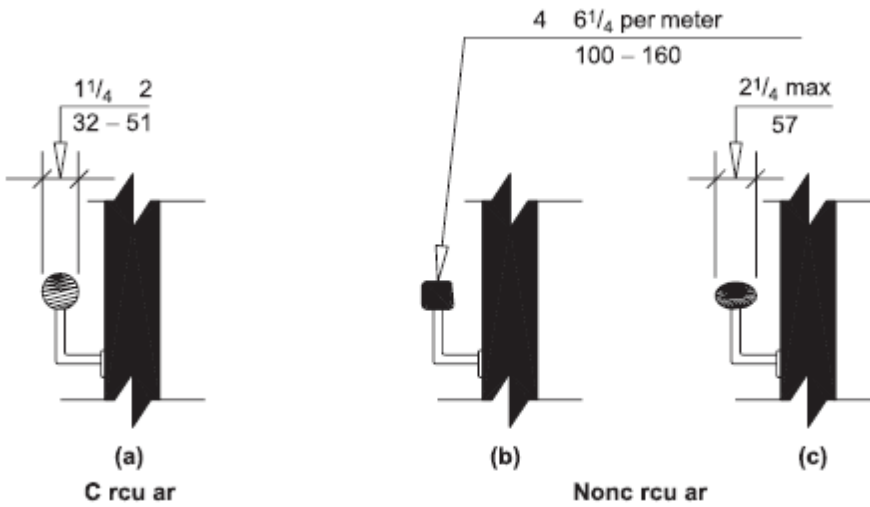

(a)
Curved

(b)

(c)

**Fig. 505.7
Handrail Cross Section**

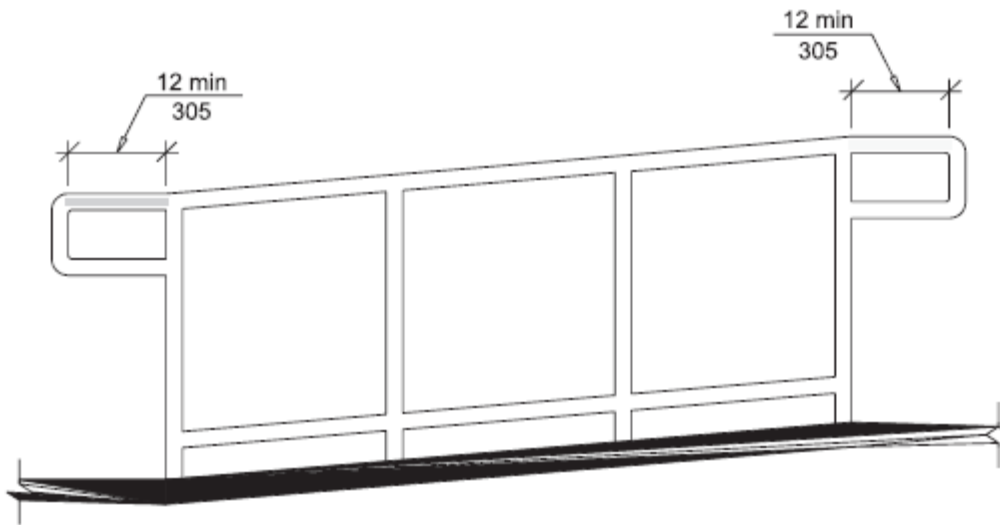
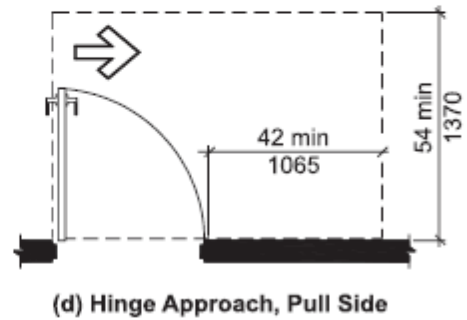
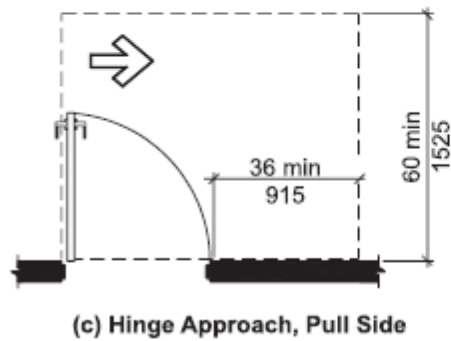
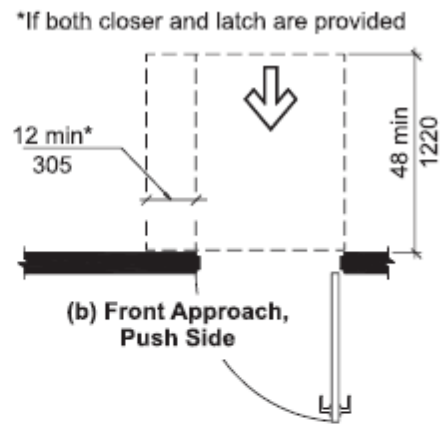
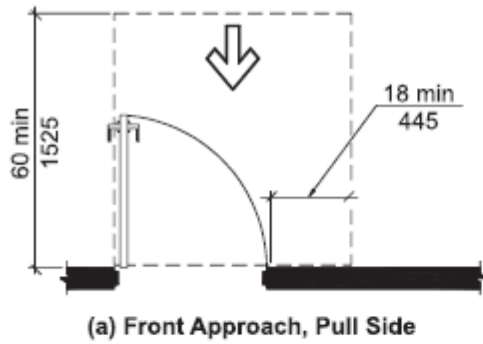

Fig. 505.10.1
Top and Bottom Handrail Extensions at Ramps



* If both closer and latch are provided
** 48 min (1220) if both closer and latch provided

RAMPS

Construction & Structural: Ramps for Single Family Dwellings may be constructed as would be residential decks. Ramps for multi-family and commercial applications shall be constructed with minimum 100 psf live load.

Slope & Rise: Ramps shall have a slope not less than 1:12. The rise for any ramp run shall be 30" maximum at which point a landing is required.

General: Floor surfaces shall be stable, firm and slip resistant.

Clear Width: The clear width of a ramp shall be 36" minimum between handrails or as required based on egress loads.

Landings: Ramps shall have level landings at bottom and top of each run. Landings shall have the following features:

- Slope - Cross slope shall not be steeper than 1:48.
- Length - Landings shall have a clear length of 60".
- Width - Clear width of landings shall be at least as wide as the ramp.
- Doorways - Typical 5' x 5' landing @ door with 18" clear floor space @ latch pull side of door.
- Landing height - Landing shall be constructed @ same height as inside floor.
- Door thresholds - Maximum height of ½" for multi-family & commercial ramps.

Handrails: Ramps with a rise greater than 6" shall have compliant handrails.

Wet Conditions: Ramps and landings subject to wet conditions shall be designed to prevent the accumulation of water. (note: max slope 1:48)

Edge Protection: Edge protection shall be provided on each side of ramps and landings.

The floor surface of the ramp run or the ramp landing shall extend 12" minimum beyond the inside face of a railing as depicted in attached drawings -or- A curb or barrier shall be provided that prevents the passage of a 4" sphere within 4" of the ramp or ramp landing floor.

Guards: Ramps and landings 30" or more above the ground shall be provided with guards.

Multi-family & commercial guards shall be 42" minimum height (36" SFD). Balusters shall be installed such that a 4" diameter sphere may not pass thru any opening up to 34" above the ramp run or landing.

Handrails: Handrails for ramps shall be as depicted in drawings and as noted below and shall be provided on both sides of ramps.

- Handrails shall be continuous within the full length of each ramp run.
- Inside handrails on switchback or dogleg ramps shall be continuous between ramp runs.
- Top of gripping surfaces shall be 34" minimum to 38" maximum vertically above ramp surfaces. Handrails shall be at a consistent height above ramp surfaces.
- Clear space between handrail and wall shall be 1 ½" minimum.
- Gripping surfaces shall be continuous, without interruption by newel posts, other construction elements or obstructions.
- Handrails shall have a circular cross section with an outside diameter of 1 ¼" minimum and 2" maximum; or shall provide equivalent graspability as follows: Other shapes shall be permitted provided they have a perimeter dimension of 4" minimum and 6 ¼" maximum, and provided the largest cross-section dimension is 2 ¼" maximum.
- Handrails and adjacent surfaces shall be free of sharp or abrasive elements. Edges shall be rounded.

Handrail Extensions: Handrails for multi-family and commercial ramps shall have compliant handrail extensions. Ramp handrails shall extend horizontally 12" minimum beyond the top & bottom of ramp runs. Such extensions shall return to a wall, guard or the floor, or shall be continuous to the handrail of the adjacent ramp run.